

FLEXIBLE COUPLING DETAILS

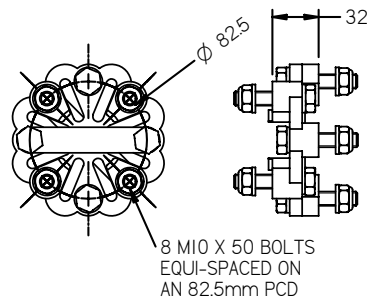

FLEXIBLE MOUNT DETAILS

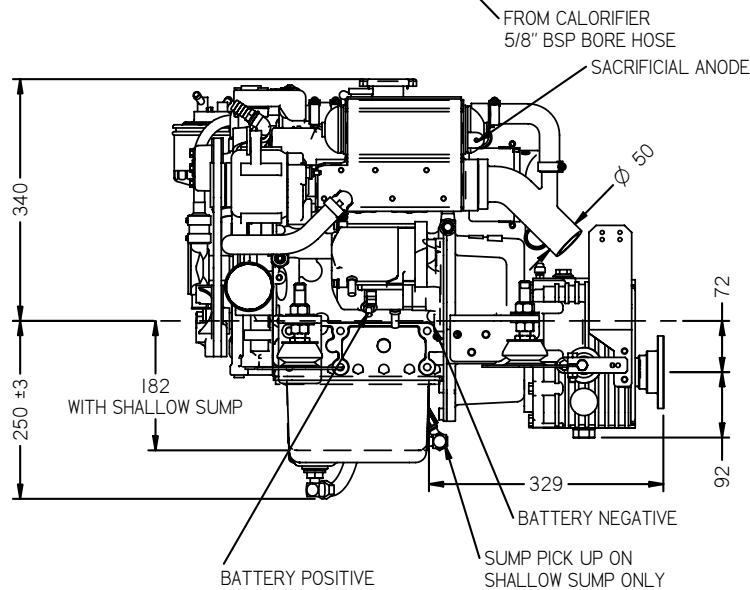
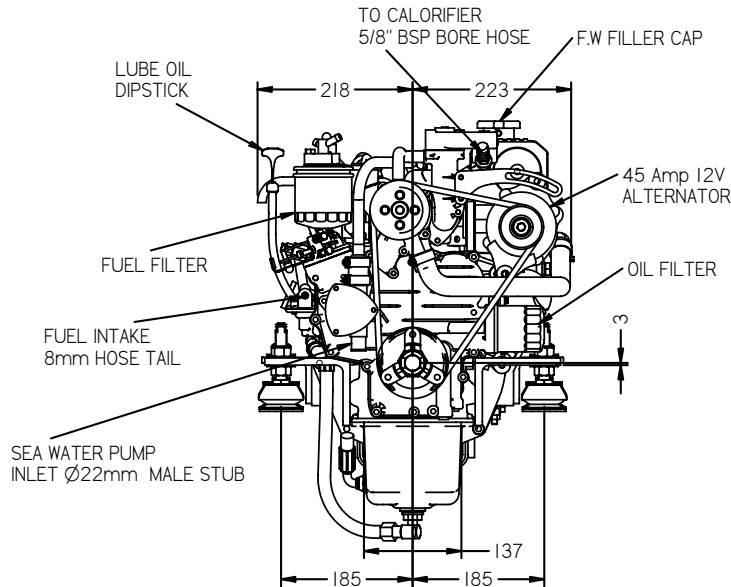
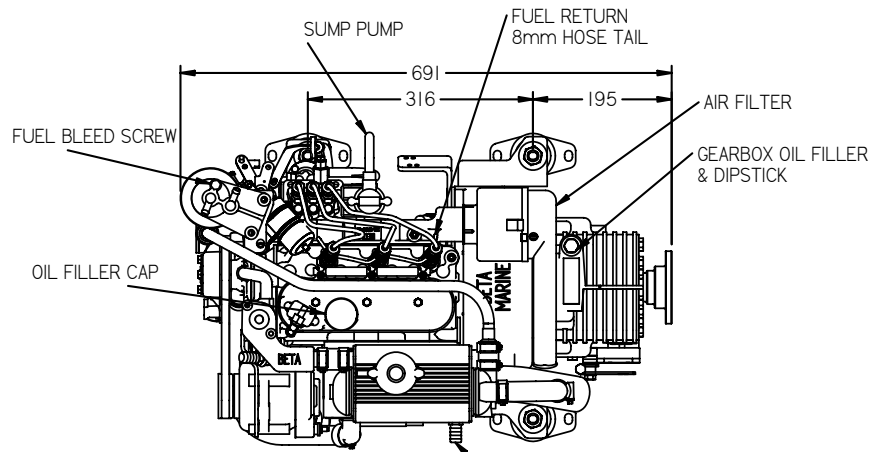
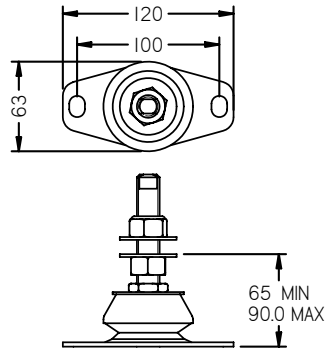

GEARBOX OUTPUT

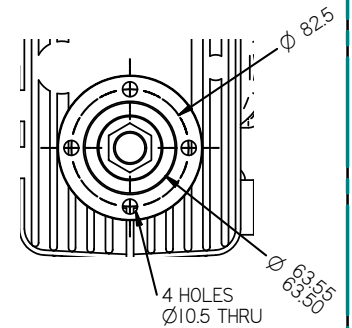

REV	DESCRIPTION	DATE	APP'D	DRAWN	NOTES
01	BATTERY CONNECTIONS AND WASTING ANODE	08-12-05	LT	TW	
02	FUEL FILTER, TANK AND AIR FILTER	25/07/05	LT	TW	
03	CALORIFIERS AND TIER2 CLOSED BREATHER	20/12/05		TW	

DIMENSIONS IN MM (INCH)
DO NOT SCALE

BETA MARINE LTD.
MERRETT'S MILLS,
BATH ROAD,
SOUTH WOODCHESTER,
STROUD, GLOS. GL5 5EU

TEL: (01453) 835282 FAX: (01453) 835284

TITLE

**BD722 HEAT EXCHANGE
PRM80 GEARBOX**

DRAWN BY: TW
CHECKED BY: -

SIZE A4
SCALE

DWG NO. 100-01048
PAGE 1 of 1

REV 03
DATE 20/12/2005